



DRILLING

TRICONE BIT

**Sustainable Improvements
Beyond Your Expectations**



About Us



JSI mainly produces rock drilling tools for mining, construction, and related industries. Meanwhile, JSI also provides rock drilling equipment and pneumatic tools based on its over 20 years servicing experience. Since its foundation in 1997, JSI has been striving to provide customers with fast, stable and economical solutions for drilling equipment, and effectively helps them reduce their total drill cost.

With constant efforts of years, not only does JSI own its own factories and laboratory but also has established strategic partnership with a number of outstanding raw material vendors. We can offer customers the most suitable solution based upon the full understanding of their specific requirements, and a wide range of actual performance tests of our products under the rigorous control on production quality and supplying system.

JSI gains high reputation from customers both at home and abroad by implementing a customer-oriented business philosophy. Now JSI's customers come from more than 70 countries, making JSI the leading exporter of rock drilling tools in China. JSI also pays great attention to quality improvement of products and push the development of Chinese rock drilling industry. JSI has won a lot of rewards from National competent authorities.

JSI people always pursue the principle that everything we do must conform to objective facts, never exaggerate and hide facts, and be honest when facing problems.

JSI will give its commitment to the customers, employees as well as society.





DRILLING Contents

02 TECHNICAL KNOWLEDGE

12 PRODUCT INTRODUCTION

28 OPERATION INSTRUCTION

36 FAILURE ANALYSIS

I Overview

1. Introduction

Mining tricone bit is one of the main tools for blast hole and well drilling. Its life span and performance whether suitable for drilling or not, that has a great influence about the quality, speed and cost of drilling project.

The rock breakage by the tricone bit which used in mine is working with both the impact of teeth and the shear caused by slippage of the teeth, which bring high rock breaking efficiency and the low operation cost.

The tricone bits developed and manufactured by our company are mainly used for large-scale open-pit mining, such as open-pit coal mines, iron mines, copper mines and molybdenum mines, also the non-metallic mines. With the increasing in variety of type, it's also widely used in quarrying, foundation clearing, hydrogeological drilling, coring, tunneling in railway transportation department and shaft drilling in underground mines.

2. Working theory

Tricone bit is connected with the drill pipe and rotates along with it, and drive cones which pressed on the rock together. Each cone rotates round the axis of its leg and simultaneously revolves around the bit center. The tungsten carbide inserts or steel teeth on the cone shell cause the formation to spall under the drill weight and the impact load from cone rotation, the cuttings will be discharged out of hole by compression air or with agent such as foam.

Each carbide insert or steel teeth pressed into the rock once with a certain depth of spall-pit on the rock. This limited depth of spalling seems to be approximately equal to the penetration depth per rotation of the bit. The teeth shape, the groove width and the crest length are all critical factors for rock breaking. With a comprehensive consideration of those factors such as the weight, RPM and air volume required for removing cuttings from the hole, the designers may reasonably manipulate the interrelationships among them and make the bits gain highly efficient penetration rate and longer service life and achieve optimum economic results.

3. Product development process

For the development of new product, the Bit Research Institute has firstly to conduct the drill ability test and various other experiments in laboratory, based upon the characteristics of ore and rock samples from mines and then, trial manufacture 2-3 samples after review of design term. The second step is testing the samples on the mines to collect technical data for analysis. The Bit Research Institute improves the design according the data feedback, then; send to Manufacture Dept. to produce in small amount base on the data. During the production, the product should process strictly according the design and requirements, then; a second time test at the mines. Change design-Produce-Test, this goes repeatedly until the end user satisfied.

4. Determination of main technical parameters

When designing a tricone bit, it's necessary to determine the size of the hole to confirm the diameter of tricone bit, so the diameter of the drilling hole is the mainly basis for design a tricone bit. Then, the other parts are designed according to the main parameters. The diameter of bit is determined by following elements: (1) Axis inclination β ; (2) Axis deviation value S ; (3) C point size C ; (4) Diameter D of tricone bit.

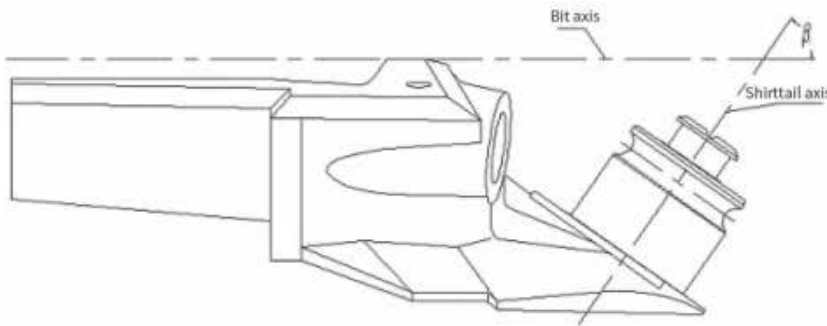

(1) Axis inclination β

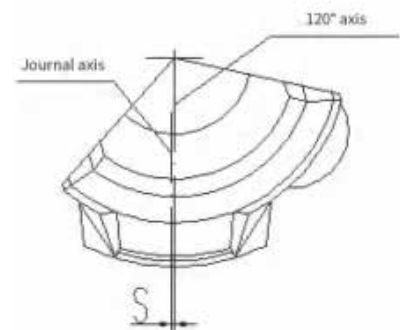

(2) Axis deviation value S

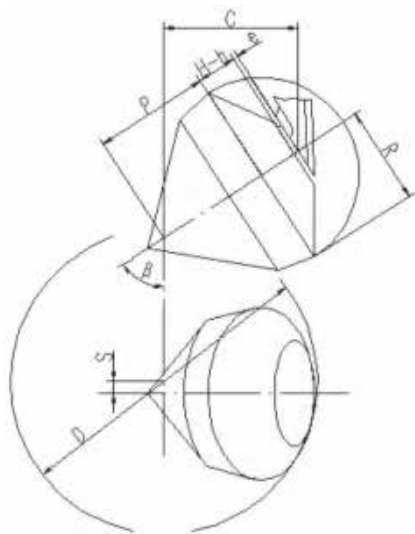

(3) C point size C

$$S \cdot \tan \delta + r \cdot \sin^2 \beta \cdot \delta = P \cdot \sin \beta \cdot \cos \beta$$

$$D = 2 \cdot \sqrt{(P \cdot \sin \beta + r \cdot \cos \beta \cdot \sin \delta)^2 + (S + r \cdot \cos \delta)^2}$$

$$P = \frac{C}{\sin \beta} - L - e$$

(4) Diameter D of tricone bit

The diameters are accurately calculated by meshing diagram and bottom hole crashing chart (covering coefficient). The shape of carbide insert, and its height, numbers will be designed according to the different rock formation.

5. Drill bit structure and characteristics

5.1 Bit structure

Normally, blast hole bit is composed of three shirrtail(3) and three intermeshing cones(9) mounted on the journals by bearings(5,6), and guided sleeve. The pin connection or shank(1) is connected with the drill pipe. Identification data(brand, type, size, serial number and date etc.) and stamped on the top surface of pin connection.

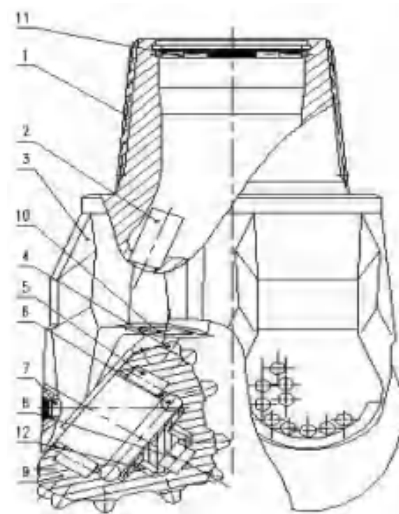

1. Pin connection
2. Oil tube
3. Shirrtail
4. Carbide
5. Roller bearing
6. Ball bearing
7. Thrust plug
8. Thrust block
9. Cone
10. Nozzle
11. Back flow valve
12. Guided sleeve

The inlaid tungsten carbide inserts (4) on cone are the means of the bit to break the formation directly. The choice of insert shapes and sizes depends on the physical and mechanical characteristics of formations to be penetrated. The cone rotated round the journals with the help of roller bearing (5), ball bearing (6), and guide sleeve (12). Through the bearing journals, the drill weight is transmitted to the inserts in turn acts on the formation. The radical load is mainly carried by journal bearings, and guide sleeve and the cones are chiefly supported by the ball bearings, which, in some cases, must also be able to with stand both radial and thrust loads. Ball bearing are loaded through the plug hole and retained by thrust plugs (7), there is thrust block on both end of guide sleeve, and a thrust block inner the cone. The friction pin bearing is used to withstand the longitudinal thrust.

For minimizing abrasive wear, wear-resistance carbide inserts are inlaid in the shirrtail and tungsten carbide as material welding on that is applied.

5.2 Bit characteristics

5.2.1 Cutting structure

According to Protodrakonv scale of rock hardness to choose different kind of insert and material formation to guarantee the abrasive performance and optimum tenacity of carbide.

Equalized the working load on the bit through a reasonable design of insert distribution on the cone by computer simulation of bottom hole crashing curve.

Install gauge bevel inserts, that is, a rows of gauge bevel inserts are distribute in back of the cone, to intensive gauge protected.

5.2.2 Bearing structure

There are two series of tricone bit in JSI, sealed and non-sealed (open).

(1) Sealed bearing

The sealed bearing is sealed by O ring, and the bearing is under the lubrication friction state by means of vacuum oil injection and other measures, which can reduce the bearing wear and extend the service life.

Structure: O ring--large pin roller -- steel ball -- two thrust block (pin roller) -- sliding (or small roller) -- a total of five bearings thrust. The O ring seal can isolate the bearing from the external environment and prevent cuttings, air and water from entering the bearing.

(2) Unsealed (open) bearings

Bearing system is non-sealing (open type) : large pin roller --steel ball -- two thrust blocks – sliding (or pin roller) - a total of five bearings, the cuttings discharged by air tube. The inner cavity of unsealed (open, the tricone bit is designed with an air flow distribution system. The air pressure of the drill rig enters the inner cavity through the drill pipe, and most of the air pressure is blown to the bottom of the hole by three replaceable nozzles (10) on the side of the shirrtail. The rock chips is discharged from the annular space between the hole wall and the drill pipe to the surface. The other parts of the air pressure enter the bearing through air-screen tube and tube of shirrtail to cool the bearing and flush the rock chips.

The structure of tricone bit of our company is designed with insert teeth, gauge protect and roller bearing, and adopts pressure air to discharge cuttings, has the advantages of high penetration rate and durability. At the same time, this kind of structure can improve the bearing capacity and bit resistance by welding and embedding wear-resistant carbide and reducing carbide on the bearing surface of shirrtail and Cone.

6. Application standard and IADC code

Our tricone bit is named according to the national standard, also coincide with the IADC code criteria.

Tricone bit is divided into steel teeth and carbide insert. The drill bit classification number is composed of three digits, the first is the formation series number, the second is the formation classification number, and the third is the structural feature code.

8 formation series number

Type	Formation Series No.	Pri.Hardness coefficient (f)	Recommended axial compression on bit OD/cm (N)	Recommended speed (r/min)
Steel tooth bit	1	1~4	1960~3920	90~120
	2	3~5	1960~4900	90~120
	3	5~7	2940~6870	90~120
Insert bit	4	6~8	3430~7850	90~120
	5	8~10	3920~8340	80~120
	6	10~12	4900~8830	60~100
	7	12~16	5880~11770	50~80
	8	16~20	6870~14710	50~80

4 stratigraphic classification numbers

Bit type number	1	2	3	4	
The abrasiveness of rocks	weak	→			strong

7 structural features code for mining tricone bits

Structural features	1	2	3	4	6	7	8
Name	Standard roller bearing	Air roller bearing	Gauge protect roller bearing	Seal roller bearing	Gauge protect seal roller bearing	Sealed sliding bearing	Labyrinth seal sliding bearing

II The lithology analysis

1 . Drillability of mineral rock

The physical mechanics properties of various formations are quite different which causes rotary drilling much difficult or easy. Some formations with low strength and high brittleness are very easy to break and some formations with high abrasion and great toughness are difficult to drill. Its particular drilling characteristics are called as its drill-ability.

Drill-ability index is an important basis for bit type selection, new bit design, formulating drilling operations specifications and estimating drilling costs.

Drill-ability not only depends on rock properties, but also the sizes, shapes and materials of drilling tools, and it is also related to drilling conditions and drilling parameters.

2. Rock hardness

Hardness is a lithology that varies with the size, shape, arrangement and bonding of the material. Harder rocks are often harder to penetrate, but some hard rocks are easier to penetrate than soft ones, so the hardness of the rock cannot be the only measure of drill-ability.

3. Rock strength

The strength properties of rock, such as compressive strength, tensile strength and shear strength, have been widely used to assess the drill-ability index. During the perforation process, the rock is either compressed or stretched or broken because the shear stress exceeds the corresponding strength limit of the rock itself.

4. The elastic

When the external force is eliminated, the original shape, volume and performance can be restored, and the elasticity makes the rock hard to break when subjected to impact.

5. Brittle

When external forces eliminate almost no residual deformation of the rock performance is called brittleness for brittle rocks, the energy consumed by rock deformation is reduced and the perforation is easy. Rock brittleness is related to stress and load.

6. Plasticity and toughness

The property that the rock has obvious residual deformation before breaking is called plasticity. The ability of a rock to resist external forces to break it into pieces is called toughness. Rocks with greater toughness in plasticity are less susceptible to deformation.

7. Abrasion

Abrasion affects rock drill ability greatly. As rock abrasion increases, the abrasion rate of bit is speeded up and the penetration rate is slowed down. With the increase of quartz content, the abrasion of the rock will go up. It is the very reason that why the drill ability of sandstone, graite and quartzite with large amounts of quartz is so poor.

8. Test method for drillability of single-tooth compression

Bit element Penetration Study can basically reflect the main characteristics that the teeth fracture and crush the rock under static pressure. For comparison with the drill ability index made by Dresser Co. USA, we adopt Morris method.

A bit element, a 90°conical tungsten carbide insert, with a 3.17mm radius at the apex, was pressed into a smooth and flat surface of rock sample prepared with a certain method. The penetration and crater depth were recorded by multichannel universal amplifier and X-Y recorder. Typical crater depth and WOB curves are shown in following figures.

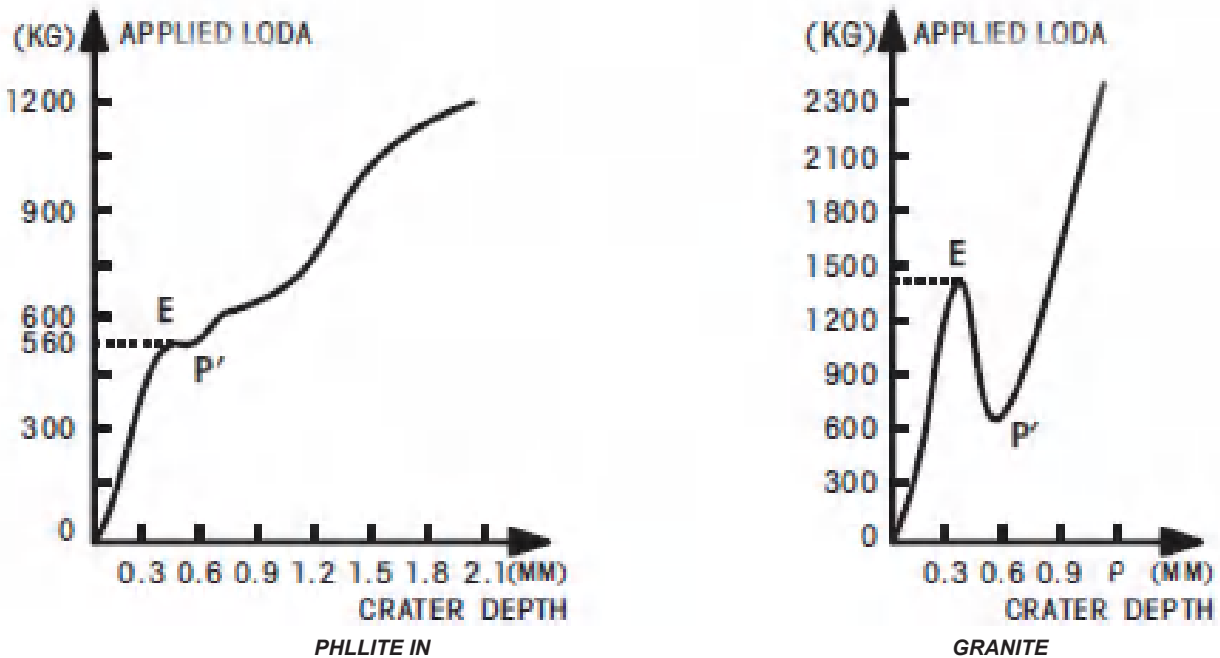

When the bit pressure reaches the critical value, the pressure input and the bit pressure become linear. Since the crushed rock is extruded from under the pressure head, the bit pressure reaches the value of E, and the amount of compaction increases sharply to P'. The relationship between the pressure penetration depth P' and the critical bit pressure E can be directly considered as the drill-ability of rock by the cone bit, and P' / E is used as the drillability index.

The type of bit, critical bit pressure and predicted drilling speed can be determined by using P 'and E values to estimate bit life.

The critical bit pressure, E, is multiplied by the number of working teeth of the bit, I, to obtain the total bit pressure, W

$$W=E \times I$$

It should be noted that W is the basic working pressure required for bit, not the most reasonable pressure.

Observation and study of the working tooth data of bit showed: $I= 0.08C$

Which: C -- the number of total teeth

The drilling speed can be expressed in the following formula:

$$V = 112.5N \cdot \left(\frac{p'}{E} \right) \left(\frac{W}{C} \right) \text{ /feet/hour}$$

N——R PM C——total number of insert W——The total weight on bit

P'——Actual depth of impression E——Threshold drill weight

There is a certain error, about 25%, between the penetration rate calculated from above equation and the primary one. This is because the samples cannot completely represent the drilled formations and their characteristics.

III Manufacturing process

1 . Main parts manufacturing process

1.1 Manufacturing Sequence of Leg:

Normalizing—— milling120 degrees —— the rough And fine turning of journal, surface weld wear-resistant alloy——milling oil mold-- drill oil hole —— carburizing, quenching—— fine milling 120 degrees —— grinding journal—— inspection.



1.2 Cone processing process:

Normalizing——Rough, fine turning of inside hole——Rough, fine turning of surface——Carburizing, quenching——hinge tooth holes——insert—— grinding inner hole——testing and inspection.



1.3 Assembly process:

Inspection of bearing parts——parts cleaning——bearing system assembly ——general assembly—— welding——Shank threading——installation nozzle——stamping serial number——paint— greasing,packing for delivery.

The tricone bit bears large load, the working conditions are harsh, the bearing system is complex, and the bit is difficult to manufacture. The cone and the leg are made of chromium, nickel and carburized alloy steel. The roller and ball are made of high strength spring steel. The guided sleeve is made of heat-resistant steel, the inner thrust block of the shirttail and the inner hole of the cone are made of cemented carbide, and the teeth are made of tungsten carbide of different grades to ensure the quality of the bit.

2 . Quality management

Quality management is the total quality control of tricone bit from raw material purchase to package delivery.

For example: Strictly control the precision of bearing system size of bit is not lower than national standard. When the end face of the small spindle of the shirttail is in contact with the thrust block of the inner hole of the cone, the maximum clearance value of the sliding amplitude of the other plane is strictly controlled within the specified range to ensure the reliable quality of the product.

3 . Physical and chemical analysis

The material heat treatment laboratory is responsible for the analysis and testing raw materials of drill bit, purchased parts and thermal processing.

(1) Spectrometers for steel elemental analysis;

(2) Physical test of carbide;

(3) The carbon concentration, carbon depth and carbon gradient of the carburized parts shall be strictly controlled within the scope of the drawing design. The hardness of the hardened parts is 100% tested and controlled in the technical documents.

IV Economic analysis

4.1 Economic analysis of drilling for mining

What is the economic effect of a rotary drill piercing? This is an issue of great concern. It has been proved that the rotary drill is more advanced drilling equipment. In addition, the perforation rate is 10 times faster than churn drilling and also faster than the donw-the-hole drill rig when the rock formation is soft and the hole range is big. Moreover, the cost per hole drilling is lower than the churn drilling rig and the down-the-hole drilling rig.

4.2 Calculation of perforation cost:

The drilling cost of rotary drill rig is divided into two categories: rig cost and bit cost:

(1) Rig cost includes depreciation cost, power cost, salary, maintenance cost, spare parts purchase cost, management cost, etc.

(2) Bit cost is the price of bit and includes inventory cost.

Drilling cost per meter is the sum of the above expenses, including all expenses related to drilling.

The formula is $C = (R \times T + B) / F$.

C—Drilling cost per meter (USD/meter)

R—Operating cost of drill rig per hour (USD/hour)

T—Bit service time (hours)

B—Bit selling price (USD)

F—Drill footage (m)

The above formula indicates that the drilling cost per meter is directly proportional to drill operating cost, bit price and drilling time of bit, but inversely proportional to the total footage of bit. Here, the penetration rate is not directly expressed, but indirectly reflected in the drilling time of bit and the total footage. High penetration rate means that higher footage can be obtained within less time. Therefore, penetration rate has a great influence upon the drilling cost per meter.

I Model specification

1. Applicable standards

JSI tricone bits comply with Chinese national standard GB/T 13343-2008 and international drilling contractor association-IADC code.

Formation series No.	Dia. of bit inch, mm	7 7/8" (200mm)	9" (229mm)	9 7/8" (251mm)	10 5/8" (270mm)	12 1/4" (311mm)
4			JTMI435	JTMI435	JTMI435	
5		JTMI535	JTMI545	JTMI535 JTMI545	JTMI545	JTMI545
6		JTMI635	JTMI615 JTMI635	JTMI635 JTMI645	JTMI635	JTMI645
7			JTMI735	JTMI725 JTMI735		JTMI745
8			JTMI845	JTMI835 JTMI845		

Remark : drill bits not indicated in the table that can be designed and manufactured according to customer's requirements

II Model description

Tricone bit codes

Order No. Example: JTMI635-251



Tricone bit

JTMI435-229

9"



Specification

Item	Description
Dia. of bit (inch)	9"
Dia. of bit (mm)	229
IADC CODE	435

Applications

Application for drilling in soft formations with low compressive strength and high drillability, such as shale, soft limestone, sandstone, conglomerate, soft dolomite and coal bed, etc., (Protodikonov's Hardness Coefficient of Rock $f=7$).

Parameters

IADC CODE	Bearing structure	Cutting Structure	Circulation Type
435	Roller-Ball-Second Thrust-Roller-First Thrus/Sealing, abrasion-resistance carbide button insert on bearing surface	Inner Rows: Sharp Ballistic Gage Rows: Chisel Gage Bevel Protection: Flat	Jet Air
Pin connection	Nozzel	Metric Bit Diameter	Weight
API 4 1/2"REG	Φ18 or Φ20mm (3 pcs) Interchangeable	229mm	50 KG

Bit legs protection

Bit Legs Protection Carbide alloy button insert on the legs' surface, back and top space of legs build up welding of abrasion-resistant alloy.

Operating Suggestions

Weight on Bit: 9000-36000 Lbs

Rotary Speed: 120-90 RPM

Air Back Pressure: 0.2-0.4 Mpa

Tricone bit

JTMI545-229

9"



Specification

Item	Description
Dia. of bit (inch)	9"
Dia. of bit (mm)	229
IADC CODE	545

Applications

Application for drilling in soft formations with low compressive strength and high drillability, such as shale, soft limestone, sandstone, conglomerate, soft dolomite and coal bed, etc., (Protodikonov's Hardness Coefficient of Rock $f=9$).

Parameters

IADC CODE	Bearing structure	Cutting Structure	Circulation Type
545	Roller-Ball-Second Thrust-Roller-First Thrus/Sealing, abrasion-resistance carbide button insert on bearing surface	Inner Rows: Ballistic Gage Rows: Chisel Gage Bevel Protection: Flat	Jet Air
Pin connection	Nozzel	Metric Bit Diameter	Weight
API 4 1/2"REG	Φ18 or Φ20mm (3 pcs) Interchangeable	229mm	50 KG

Bit legs protection

Bit Legs Protection Carbide alloy button insert on the legs' surface, back and top space of legs build up welding of abrasion-resistant alloy.

Operating Suggestions

Weight on Bit: 9000-36000 Lbs

Rotary Speed: 120-90 RPM

Air Back Pressure: 0.2-0.4 Mpa

Tricone bit

JTMI635-229

9"



Specification

Item	Description
Dia. of bit (inch)	9"
Dia. of bit (mm)	229
IADC CODE	635

Applications

Application for drilling in medium soft formations with low compressive strength and high drillability, such as shale, soft limestone, soft dolomite and coal bed, etc., (Protodikonov's Hardness Coefficient of Rock $f=11$).

Parameters

IADC CODE	Bearing structure	Cutting Structure	Circulation Type
635	Roller-Ball-Second Thrust-Roller-First Thrus/Sealing, abrasion-resistance carbide button insert on bearing surface	Inner Rows: Ballistic Gage Rows: Spherical Gage Bevel Protection: Flat	Jet Air
Pin connection	Nozzel	Metric Bit Diameter	Weight
API 4 1/2"REG	Φ18 or Φ20mm (3 pcs) Interchangeable	229mm	50 KG

Bit legs protection

Bit Legs Protection Carbide alloy button insert on the legs' surface, back and top space of legs build up welding of abrasion-resistant alloy.

Operating Suggestions

Weight on Bit: 27000-54000 Lbs

Rotary Speed: 100-60 RPM

Air Back Pressure: 0.2-0.4 Mpa

Tricone bit

JTMI735-229

9"



Specification

Item	Description
Dia. of bit (inch)	9"
Dia. of bit (mm)	229
IADC CODE	735

Applications

Application for drilling in hard formations with high compressive strength, hard and high abrasiveness, such as granite, limestone, sandstone, arenaceous shale, dolomite, firestone, etc., (Protodikonov's Hardness Coefficient of Rock $f=15$).

Parameters

IADC CODE	Bearing structure	Cutting Structure	Circulation Type
735	Roller-Ball-Second Thrust-Roller-First Thrus/Sealing, abrasion-resistance carbide button insert on bearing surface	Inner Rows: Ballistic, Semi Ballistic Gage Rows: Spherical Gage Bevel Protection: Flat	Jet Air
Pin connection	Nozzel	Metric Bit Diameter	Weight
API 4 1/2"REG	Φ18 or Φ20mm (3 pcs) Interchangeable	229mm	50 KG

Bit legs protection

Bit Legs Protection Carbide alloy button insert on the legs' surface, back and top space of legs build up welding of abrasion-resistant alloy.

Operating Suggestions

Weight on Bit: 27000-54000 Lbs

Rotary Speed: 100-60 RPM

Air Back Pressure: 0.2-0.4 Mpa

Tricone bit

JTMI845-229

9"



Specification

Item	Description
Dia. of bit (inch)	9"
Dia. of bit (mm)	229
IADC CODE	845

Applications

Application for drilling in extremely hard formations with high compressive strength extremely hard and high abrasiveness, such as granite, limestone, sandstone, arenaceous shale, dolomite, firestone, etc.,(Protodikonov's Hardness Coefficient of Rock f=18).

Parameters

IADC CODE	Bearing structure	Cutting Structure	Circulation Type
845	Roller-Ball-Second Thrust-Roller-First Thrus/Sealing, abrasion-resistance carbide button insert on bearing surface	Inner Rows: Spherical Gage Rows: Spherical Gage Bevel Protection: Flat	Jet Air
Pin connection	Nozzel	Metric Bit Diameter	Weight
API 4 1/2"REG	Φ18 or Φ20mm (3 pcs) Interchangeable	229mm	50 KG

Bit legs protection

Bit Legs Protection Carbide alloy button insert on the legs' surface, back and top space of legs build up welding of abrasion-resistant alloy.

Operating Suggestions

Weight on Bit: 27000-54000 Lbs

Rotary Speed: 100-60 RPM

Air Back Pressure: 0.2-0.4 Mpa

Tricone bit

JTMI435-251

9"



Specification

Item	Description
Dia. of bit (inch)	9 7/8"
Dia. of bit (mm)	251
IADC CODE	435

Applications

Application for drilling in soft formations with low compressive strength and high drillability, such as shale, soft limestone, dolomite and coal bed, etc., (Protodikonov's Hardness Coefficient of Rock $f=7$).

Parameters

IADC CODE	Bearing structure	Cutting Structure	Circulation Type
435	Roller-Ball-Second Thrust-Roller-First Thrus/Sealing, abrasion-resistance carbide button insert on bearing surface	Inner Rows: Sharp Ballistic Gage Rows: Chisel Gage Bevel Protection: Flat	Jet Air
Pin connection	Nozzel	Metric Bit Diameter	Weight
API 6 5/8"REG	Φ20 or Φ22mm (3 pcs) Interchangeable	251mm	65 KG

Bit legs protection

Bit Legs Protection Carbide alloy button insert on the legs' surface, back and top space of legs build up welding of abrasion-resistant alloy.

Operating Suggestions

Weight on Bit: 19750-49380 Lbs

Rotary Speed: 110-80 RPM

Air Back Pressure: 0.2-0.4 Mpa

Tricone bit

JTMI545-251

9"



Specification

Item	Description
Dia. of bit (inch)	9 7/8"
Dia. of bit (mm)	251
IADC CODE	545

Applications

Application for drilling in soft formations with low compressive strength and high drillability, such as shale, soft limestone, soft dolomite and coal bed, etc., (Protodikonov's Hardness Coefficient of Rock $f=9$).

Parameters

IADC CODE	Bearing structure	Cutting Structure	Circulation Type
545	Roller-Ball-Second Thrust-Roller-First Thrus/Sealing, abrasion-resistance carbide button insert on bearing surface	Inner Rows: Ballistic Gage Rows: Chisel Gage Bevel Protection: Flat	Jet Air
Pin connection	Nozzel	Metric Bit Diameter	Weight
API 6 5/8"REG	Φ20 or Φ22mm (3 pcs) Interchangeable	251mm	65 KG

Bit legs protection

Bit Legs Protection Carbide alloy button insert on the legs' surface, back and top space of legs build up welding of abrasion-resistant alloy.

Operating Suggestions

Weight on Bit: 19750-49380 Lbs

Rotary Speed: 110-80 RPM

Air Back Pressure: 0.2-0.4 Mpa

Tricone bit

JTMI635-251

9"



Specification

Item	Description
Dia. of bit (inch)	9 7/8"
Dia. of bit (mm)	251
IADC CODE	635

Applications

Application for drilling in medium hard formations with high compressive strength extremely hard and high abrasiveness, such as limestone, sandstone, dolomite, firestone, etc.,(Protodikonov's Hardness Coefficient of Rock f=11).

Parameters

IADC CODE	Bearing structure	Cutting Structure	Circulation Type
635	Roller-Ball-Second Thrust-Roller-First Thrus/Sealing, abrasion-resistance carbide button insert on bearing surface	Inner Rows: Ballistic Gage Rows: Chisel Gage Bevel Protection: Flat	Jet Air
Pin connection	Nozzel	Metric Bit Diameter	Weight
API 6 5/8"REG	Φ20 or Φ22mm (3 pcs) Interchangeable	251mm	65 KG

Bit legs protection

Bit Legs Protection Carbide alloy button insert on the legs' surface, back and top space of legs build up welding of abrasion-resistant alloy.

Operating Suggestions

Weight on Bit: 29260-59250 Lbs

Rotary Speed: 100-60 RPM

Air Back Pressure: 0.2-0.4 Mpa

Tricone bit

JTMI725-251

9"



Specification

Item	Description
Dia. of bit (inch)	9 7/8"
Dia. of bit (mm)	251
IADC CODE	725

Applications

Application for drilling in medium hard formations with high compressive strength and high abrasiveness, such as limestone, sandstone, dolomite, firestone, etc., (Protodikonov's Hardness Coefficient of Rock $f=14$).

Parameters

IADC CODE	Bearing structure	Cutting Structure	Circulation Type
725	Roller-Ball-Second Thrust-Roller-First Thrus/Sealing, abrasion-resistance carbide button insert on bearing surface	Inner Rows: Ballistic Gage Rows: Spherical Gage Bevel Protection: Flat	Jet Air
Pin connection	Nozzel	Metric Bit Diameter	Weight
API 6 5/8"REG	Φ20 or Φ22mm (3 pcs) Interchangeable	251mm	65 KG

Bit legs protection

Bit Legs Protection Carbide alloy button insert on the legs' surface, back and top space of legs build up welding of abrasion-resistant alloy.

Operating Suggestions

Weight on Bit: 39500-59000 Lbs

Rotary Speed: 90-60 RPM

Air Back Pressure: 0.2-0.4 Mpa

Tricone bit

JTMI835-251

9"



Specification

Item	Description
Dia. of bit (inch)	9 7/8"
Dia. of bit (mm)	251
IADC CODE	835

Applications

Application for drilling in extremely hard formations with high compressive strength extremely hard and high abrasiveness, such as limestone, sandstone, dolomite, firestone, etc.,(Protodikonov's Hardness Coefficient of Rock f=18).

Parameters

IADC CODE	Bearing structure	Cutting Structure	Circulation Type
835	Roller-Ball-Second Thrust-Roller-First Thrus/Sealing, abrasion-resistance carbide button insert on bearing surface	Inner Rows: Spherical Gage Rows: Spherical Gage Bevel Protection: Flat	Jet Air
Pin connection	Nozzel	Metric Bit Diameter	Weight
API 6 5/8"REG	Φ20 or Φ22mm (3 pcs) Interchangeable	251mm	65 KG

Bit legs protection

Bit Legs Protection Carbide alloy button insert on the legs' surface, back and top space of legs build up welding of abrasion-resistant alloy.

Operating Suggestions

Weight on Bit: 49370-79000 Lbs

Rotary Speed: 80-50 RPM

Air Back Pressure: 0.2-0.4 Mpa

Tricone bit

JTMI845-251

9"



Specification

Item	Description
Dia. of bit (inch)	9 7/8"
Dia. of bit (mm)	251
IADC CODE	845

Applications

Application for drilling in extremely hard formations with high compressive strength extremely hard and high abrasiveness, such as limestone, sandstone, dolomite, firestone, etc.,(Protodikonov's Hardness Coefficient of Rock f=18).

Parameters

IADC CODE	Bearing structure	Cutting Structure	Circulation Type
845	Roller-Ball-Second Thrust-Roller-First Thrus/Sealing, abrasion-resistance carbide button insert on bearing surface	Inner Rows: Spherical Gage Rows: Spherical Gage Bevel Protection: Flat	Jet Air
Pin connection	Nozzel	Metric Bit Diameter	Weight
API 6 5/8"REG	Φ20 or Φ22mm (3 pcs) Interchangeable	251mm	65 KG

Bit legs protection

Bit Legs Protection Carbide alloy button insert on the legs' surface, back and top space of legs build up welding of abrasion-resistant alloy.

Operating Suggestions

Weight on Bit: 49370-79000 Lbs

Rotary Speed: 80-50 RPM

Air Back Pressure: 0.2-0.4 Mpa

Tricone bit

JTMI435-270

10"



Specification

Item	Description
Dia. of bit (inch)	10 5/ 8"
Dia. of bit (mm)	270
IADC CODE	435

Applications

Application for drilling in soft formations with low compressive strength and high drillability, such as shale, soft limestone, dolomite and coal bed, etc.,(Protodikonov's Hardness Coefficient of Rock f=7).

Parameters

IADC CODE	Bearing structure	Cutting Structure	Circulation Type
435	Roller-Ball-Second Thrust-Roller-First Thrus/Sealing, abrasion-resistance carbide button insert on bearing surface	Inner Rows: Sharp Ballistic Gage Rows: Ballistic Gage Bevel Protection: Spherical	Jet Air
Pin connection	Nozzel	Metric Bit Diameter	Weight
API 6 5/8"REG	Φ20 or Φ22mm (3 pcs) Interchangeable	270mm	74 KG

Bit legs protection

Bit Legs Protection Carbide alloy button insert on the legs' surface, back and top space of legs build up welding of abrasion-resistant alloy.

Operating Suggestions

Weight on Bit: 10630-21250 Lbs

Rotary Speed: 120-90 RPM

Air Back Pressure: 0.2-0.4 Mpa

Tricone bit

JTMI545-270

10"



Specification

Item	Description
Dia. of bit (inch)	10 5/ 8"
Dia. of bit (mm)	270
IADC CODE	545

Applications

Application for drilling in soft formations with low compressive strength and high drillability, such as shale, soft limestone, dolomite and coal bed, etc.,(Protodikonov's Hardness Coefficient of Rock f=9).

Parameters

IADC CODE	Bearing structure	Cutting Structure	Circulation Type
545	Roller-Ball-Second Thrust-Roller-First Thrus/Sealing, abrasion-resistance carbide button insert on bearing surface	Inner Rows: Sharp Ballistic Gage Rows: Ballistic Gage Bevel Protection: Spherical	Jet Air
Pin connection	Nozzel	Metric Bit Diameter	Weight
API 6 5/8"REG	Φ20 or Φ22mm (3 pcs) Interchangeable	270mm	74 KG

Bit legs protection

Bit Legs Protection Carbide alloy button insert on the legs' surface, back and top space of legs build up welding of abrasion-resistant alloy.

Operating Suggestions

Weight on Bit: 21250-53130 Lbs

Rotary Speed: 110-80 RPM

Air Back Pressure: 0.2-0.4 Mpa

Tricone bit

JTMI635-270

10"



Specification

Item	Description
Dia. of bit (inch)	10 5/ 8"
Dia. of bit (mm)	270
IADC CODE	635

Applications

Application for drilling in medium hard formations with high compressive strength medium hard and high abrasiveness, such as limestone, sandstone, dolomite, firestone, etc.,(Protodikonov's Hardness Coefficient of Rock f=11).

Parameters

IADC CODE	Bearing structure	Cutting Structure	Circulation Type
635	Roller-Ball-Second Thrust-Roller-First Thrus/Sealing, abrasion-resistance carbide button insert on bearing surface	Inner Rows: Sharp Ballistic Gage Rows: Ballistic Gage Bevel Protection: Spherical	Jet Air
Pin connection	Nozzel	Metric Bit Diameter	Weight
API 6 5/8"REG	Φ20 or Φ22mm (3 pcs) Interchangeable	270mm	74 KG

Bit legs protection

Bit Legs Protection Carbide alloy button insert on the legs' surface, back and top space of legs build up welding of abrasion-resistant alloy.

Operating Suggestions

Weight on Bit: 31880-63750 Lbs

Rotary Speed: 100-70 RPM

Air Back Pressure: 0.2-0.4 Mpa

Tricone bit

JTMI645-311

12"



Specification

Item	Description
Dia. of bit (inch)	12 1/4"
Dia. of bit (mm)	311
IADC CODE	645

Applications

Application for drilling in medium hard formations with high compressive strength and high abrasiveness, such as limestone, sandstone, dolomite, firestone, etc., (Protodikonov's Hardness Coefficient of Rock $f=11$).

Parameters

IADC CODE	Bearing structure	Cutting Structure	Circulation Type
645	Roller-Ball-Second Thrust-Roller-First Thrus/Sealing, abrasion-resistance carbide button insert on bearing surface	Inner Rows: Sharp Ballistic Gage Rows: Ballistic Gage Bevel Protection: Flat	Jet Air
Pin connection	Nozzel	Metric Bit Diameter	Weight
API 6 5/8"REG	Φ22 or Φ24mm (3 pcs) Interchangeable	311mm	98.5 KG

Bit legs protection

Bit Legs Protection Carbide alloy button insert on the legs' surface, back and top space of legs build up welding of abrasion-resistant alloy.

Operating Suggestions

Weight on Bit: 46000-83000 Lbs

Rotary Speed: 90-60 RPM

Air Back Pressure: 0.2-0.4 Mpa

Tricone bit

JTMI745-311

12"



Specification

Item	Description
Dia. of bit (inch)	12 1/4"
Dia. of bit (mm)	311
IADC CODE	745

Applications

Application for drilling in hard formations with high compressive strength hard and high abrasiveness, such as granite, limestone, arenaceous shale, dolomite, firestone, etc.,(Protodikonov's Hardness Coefficient of Rock f=15).

Parameters

IADC CODE	Bearing structure	Cutting Structure	Circulation Type
745	Roller-Ball-Second Thrust-Roller-First Thrus/Sealing, abrasion-resistance carbide button insert on bearing surface	Inner Rows: Sharp Ballistic Gage Rows: Spherical Gage Bevel Protection: Flat	Jet Air
Pin connection	Nozzel	Metric Bit Diameter	Weight
API 6 5/8"REG	Φ22 or Φ24mm (3 pcs) Interchangeable	311mm	98.5 KG

Bit legs protection

Bit Legs Protection Carbide alloy button insert on the legs' surface, back and top space of legs build up welding of abrasion-resistant alloy.

Operating Suggestions

Weight on Bit: 49000-85000 Lbs

Rotary Speed: 80-50 RPM

Air Back Pressure: 0.2-0.4 Mpa

I Operating parameters

1 . The weight on bit (WOB)

The drill-ability test method mentioned above can be used to estimate the bit pressure in theory, but the actual bit pressure is related to other factors.

There are three crushing zones in middle and extreme hard rock:

- (1) The rocks were worn and broken by friction
- (2) The rock has been subjected to repeated load fatigue fracture
- (3) Enough WOB to crush the rock

Recommended relationship between drill pressure and perforation speed: $V = aW^M$

Type in the:

V—Penetration rate m/hr. (m/h)

W—Weight on bit (ton)

A—Factor related to RPM and rock characteristics.

M— —The coefficient related to rock hardness and cutting discharge condition

In good cutting discharge condition, and the rock is not repeatedly broken. The M value is close to 2, but in the field, the M value is 1~2.

The relationship of curves between drilling speed and drill weight on soft, medium hard formation as below;

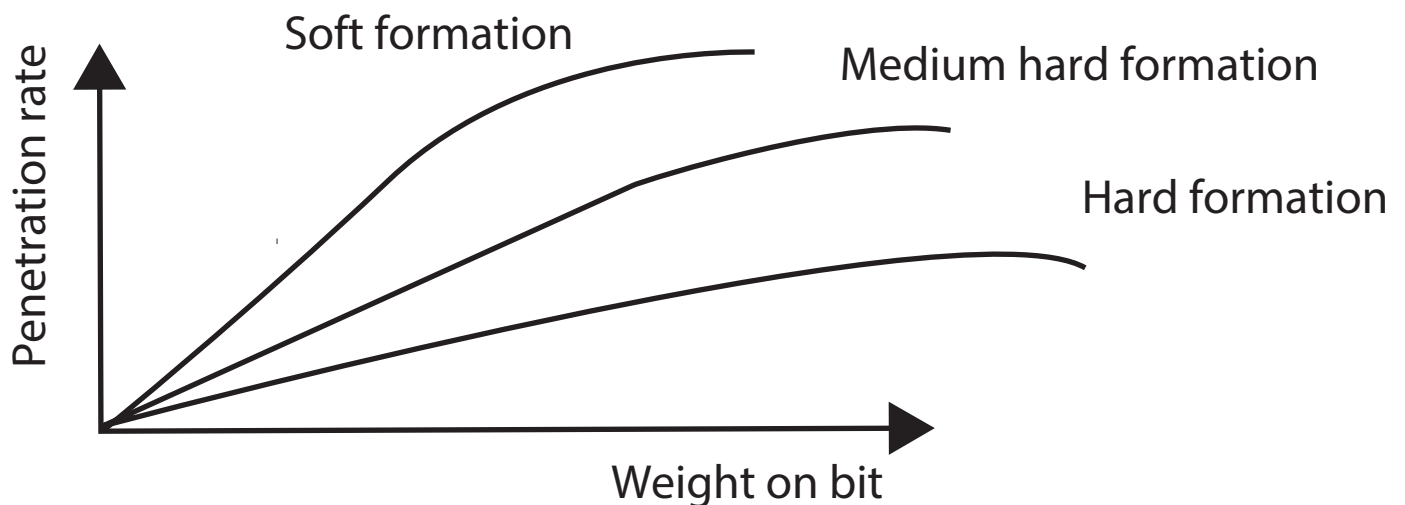

On condition that the cuttings are cleanly removed from the hole bottom, the harder the formation is, the heavier the weight for rock fracture becomes. When the weight is less than that of requirement, the formation is in abrasive and fatigue phases resulting in carbide inserts wear which creates slow penetration rate and poor bit performance. As extra weight is applied, the penetration rate will increase slightly until the carbide inserts are buried to full depth and the cone bodies founder resulting in excess erosion around the inserts, compact breakage, higher bearing loading and excess rotation torque. In this case, the bit cannot drill formation effectively.

In general, higher penetration rate can be achieved by increasing RPM rather than increasing weight. Therefore, for soft formations it is necessary to increase RPM and adapt larger air flush to clean the hole, but for hard formations, it is appropriate to increase weight and properly decrease the RPM.

The selection of drilling pressure should consider the physical and mechanical properties of rock and the drillability of rock, the bearing capacity of bit and the technical performance of drill rig.

According to practical experiences of home and abroad, recommended WOB to shown in following tables;

WOB for various formations

Rock Type	Soft	Medium hard	Hard or extra hard
Recommended WOB (kg/OD/cm)	200—700	500—900	700—1500

Recommended Weights On Bit for Various Diameters.

Drill bit O.D	Inch	5	6 1/4	6 3/4	7	7 7/8	9	9 7/8	12	12 1/4	15
	mm	127	158	171	178	200	229	251	305	311	381
Recommend WOB	lb	20000	280000	34000	35000	43000	55000	70000	75000	92000	120000
	kg	9072	12700	15422	15876	19505	24948	31752	34020	41731	54432
WOB on OD/Inch	lb	4000	4480	5037	5000	5460	6111	7089	6250	7510	8000
	kg	1814	2032	2285	2268	2477	2772	3215	2835	3407	3629

Recommended Weights for Various Formation Hardness and Diameters.

Protodikonov's Hardness of Rock(f)	WOB on different O.D drill bit(ton)	Φ200	Φ229	Φ251	Φ270	Φ311
8		10.0	11.2	12.6	14.1	16.2
10		12.5	14.0	15.8	17.6	20.3
12		14.9	16.8	19.4	21.1	24.3
14		17.4	19.6	22.0	24.6	28.4
16		19.9	22.4	25.4	28.2	32.4
18		22.4	25.2	28.6	31.6	36.4
20		24.8	28.0	31.8	35.2	40.5

2 . Rotary Speed Requirement

Experience has shown that under such circumstances that the cuttings can be well removed from the hole, the RPM possesses of a proximate linear relationship with penetration rate within a certain range. As the RPM is increased, the penetration rate will increase with relation to formation characteristics, see following figure.

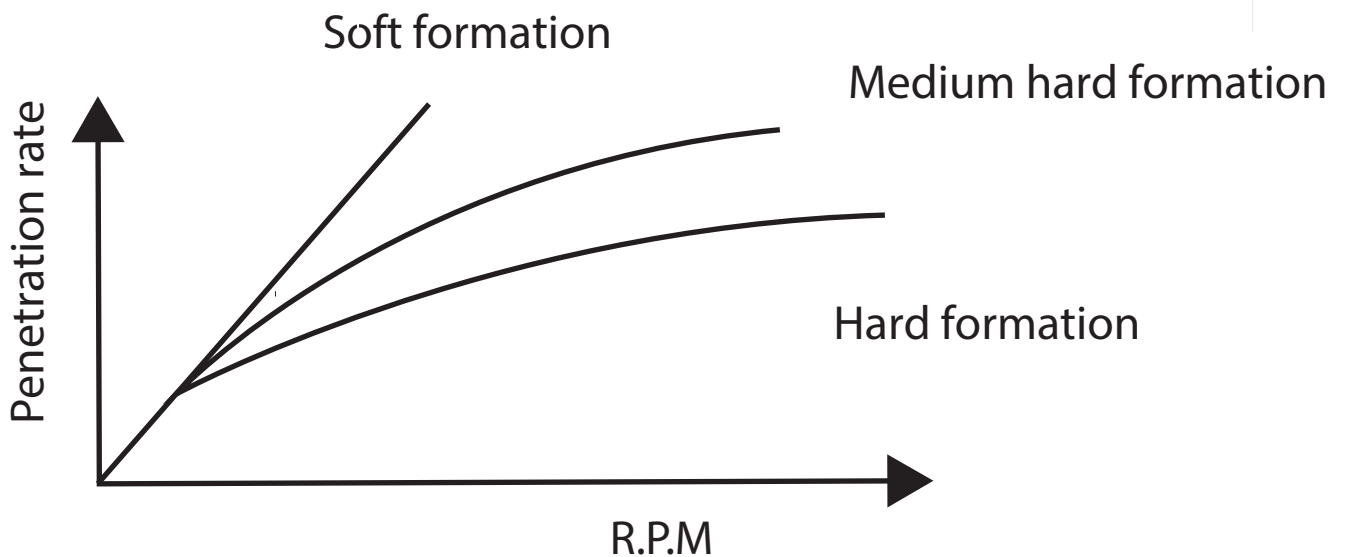

The following factors should be taken into consideration determining the RPM:

(1) In soft formations, RPM increases proportional to the penetration rate, but in medium formations, RPM increases approximately proportional for the penetration rate. It is necessary to adjust the match between weight and RPM for the increase of penetration rate. In drilling hard or extremely hard formations, however, the increase RPM will result in the increases of impact load on bit and the possibility of insert breakage. High RPM when drilling in hard and abrasive formations will cause the increase of inserts and bearings wear and lead to prominent decrease of bit life. Therefore, high RPM is used in soft formations, but lower RPM in hard formations.

(2) The characteristics of drill rig should be considered in relation to the selection of rotary speed. In hard formations, increase RPM will lead to severe vibration of drill, and cause bit and drill components failure. The bits with spherical-shaped inserts and rolling bearings can adopt higher RPM. As regards the bits with chisel-shaped inserts and plain bearings, the RPM should be lower.

Recommended RPM is as follows:

Rock Type	Soft rock	Medium hard rock	Hard rock and extremely hard rock
Speed (rotate/min)	80—120	60—100	50—80

3 . Air Requirements

Compressed air is widely used for blowing cuttings in rotary blast hole drilling rig. It serves two important functions; One is to clean and remove cuttings from the hole bottom with sufficient air volume, and the other is to cool and flush the bearing surfaces of bit for increasing rotary speed and obtaining longer bit life.

In order to remove the cuttings of certain size and specific gravity form the hole, the volume of air circulated must be sufficient to produce a certain velocity of bailing air i.e, the minimum velocity of return air in the annulus between the drill stem and the wall of the hole. $V=54600 \times \left(\frac{P}{P+62.4} \right) D^{0.6}$

Type :

V—Bailing air velocity (ft/min)

P—Unit weight of rock cutting(1b/ft³)

D—Cuttings diameter(ft)

The air volume of cutting discharge can be calculated as follows:

$$Q=0.0054V \times (D^2-d^2)$$

Where :

Q--Required bailing air volume, ft/min.

V---Bailing air velocity, ft/min.

D---Blast hole diameter, in.

d---Drill rod O.D, in.

As bailing air velocity is 5000ft/min.,

$$Q=27.272 (D^2-d^2)$$

According to blast hole diameters and drill rod sizes, calculated volumes of bailing air are shown in following form for convenient use.

D aperture		D drill pipe outside diameter		Q Air volume for cutting discharge speed 5000ft/m		Q Air volume for cutting discharge speed 7000ft/m	
inch	mm	inch	mm	Cubic Feet/min	Cubic Meter/min	Cubic Feet/min	Cubic Meter/min
9 ⁷ / ₈	251	7	177.8	1323	37.04	1852	51.86
		7 ³ / ₄	186.8	1022	28.61	1431	40.07
		8 ⁵ / ₈	219	627	17.56	878	24.58
		9	228.6	450	12.60	630	17.64
10 ³ / ₈	270	7	177.8	1742	48.78	2439	68.29
		7 ³ / ₄	186.8	1441	40.35	2017	56.48
		8 ⁵ / ₈	219	1050	29.40	1470	41.16
		9	228.6	868	24.30	1215	34.02
12 ¹ / ₄	311	8 ⁵ / ₈	219	2063	57.76	2888	80.86
		9	228.6	1882	52.70	2635	73.78
		10	254	1365	38.22	1911	53.51
		10 ³ / ₄	273	941	26.35	1317	36.88

Air pressure can be controlled by changing the size of jet nozzle in the bit. By the way, the proper air pressure can be obtained.

The size series of nozzle I.D. available from our works are:

Drill diameter (mm)	Nozzle outside diameter (mm)	Nozzle assembly length (mm)	Nozzle bore diameter (mm)
150—190	24	20	10、12、15、17
215—250	33.1	28	16、17、18、20、22
255—310	33.1	28	18、20、22、24
311—380	33.1	28	20、22、24、26

The method for nozzle replacement is shown in following figure.

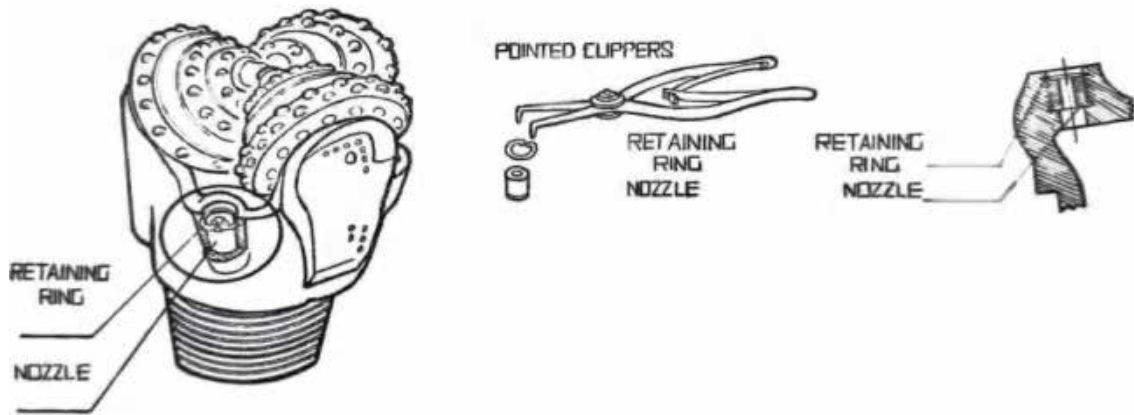

II Matters need attention

1. Make sure that the thread of bit in good conditions. Damaged thread of bit will damage the thread of drill rod. Once thread-damaged bit is found, it is necessary to get it repaired, or put it out of service for severe damage.
2. Clean the threads on bit and on drill rod, make sure that the mating shoulders are clean and doped with a high quality lubricant.

3. Inspect all the bit components, make sure that the nozzle size is correct and the nozzles are properly tightened, and teeth are perfect, the cones are not mutual-biting and no cracks are in the weld. If any faults have been found, the bit should be put out of service.
4. If tricone bit required open type, make sure the air-screen tube does not loose or drop. The bit without airscreen tube cannot be used. Once finding the air screen tube is missing, a new one should be reinstated. Otherwise, cuttings are going to enter the bearings and cause the bit failure.
5. When hole is buried by cuttings, it is necessary to remove the cuttings until bottom is clean, then drilling again.
6. When a new bit is installed, drill at reduced weight (5-10tons) for a break-in period (10-15minutes). After the break-in period, cones should be checked that all are about the same temperature. One hot cone with high temperature generally indicates that the passage to that particular bearing has become obstructed, the bit should be inspected before any damage occurs.
7. In hole collaring, less weight and lower RPM should be applied until the collar is formed. After collaring, start normal drilling, Reversal rotation of bit is forbidden to prevent bit falling down into the hole.
8. During drilling, never put wrenches, debris and metal parts on the deck for preventing them from dropping into the hole to damage bit.
9. Open air valve before lowering bit to collar the hole. Keep adequate air on until the bit has finished drilling and is out of the hole.
10. Always rotate the drill rod when moving in or out of the hole to prevent the drill rod, stabilizer and bit being damaged.
11. Never start the bit drilling under load conditions and never use the hydraulic down pressure on the bit to aid in leveling the machine. Never allow the bit to drop into the hole on the end of the drill rod, otherwise, dropping bit can cause cracking of the welds and /or indentations in the bearing races resulting in premature bearing failure.
12. Insure trouble free bearing performance, a 20 pound minimum pressure drop across the bit is desirable, i.e. the bit should add about 20psi to the cab gage over the pressure on the gage with the bit off.
13. In wet hole or where water injection is used for dust control, maintain as high a pressure drop across the bit air passage as possible(or regulate the nozzle size) and minimum amount of water to protect the bit bearings.

14. When removing from service for a certain reason, rotate the cones by hand for inspection and clean them with compressed air to insure that they turn freely before reusing.
15. A bent drill pipe or a badly worn stabilizer should not be used for drilling as they often cause bit premature failure, deviation and swaying.
16. Pay attention to the AMP meter reading. As the formation varies in Characteristic, the weight and RPM should be adjusted to prevent the teeth and bearings from damage. Lower the drill rod smoothly and slowly. While drilling, prevent the bit from jamming and jumping. Never use a new bit to drill a hole with collaring and scratch rock.
17. Increase in torque, either hydraulic pressure or AMP's, or increase in air pressure, are indications that the hole is not being cleaned. Need find out the cause and improve it solved for the improvement of cuttings cleaning effect.
18. Low r.p.m should be used when selecting high WOB, and the maximum value of WOB and r.p.m should not be chosen at the same time.
19. When the bit stay in the hole bottom for long time, it is necessary to lift the bit out of the hole and then rotate the cones to insure that they turn freely before drilling.
20. In freezing conditions and where water injection is used for dust control, water can freeze inside the bearings and air passages. The air temperature from the compressor will normally melt the ice if time is allowed before starting to drill.
21. In extremely cold climates, the drill rod and bit should be warm before the water injection is used. This will prevent the water from freezing to the cold metal surfaces.
22. When a bit is used, flush it with water firstly, then force the air through each bearing and get all bearings oiled.
23. Properly maintain the drill rod and its threaded connections. A bent drill pipe will cause excess loading on one or two cones resulting in bit early failure. Wears on one side of a drill pipe and stabilizer are also indications of the drill pipe is bent, therefore the bent drill pipe should be replaced with a new one.
24. A pressure reading with the bit off can be taken at each bit change and recorded on the drill report. A change from the prior readings will help determine if a new obstruction or a new leak has developed.
25. In process of handling, never allow a bit to drop down from the heights. When stored in the open air, the bit should be protected from water to enter their bearings.

IV Failure analysis

1. Common fault

Designers do their best for optimum design which would yield even wear of both bearings and cutters after optimum footage has been achieved. This optimum design, however, presume an average condition prevailing in a wide variety of drilling conditions in which the design is utilized.

1.1 Early wear of the shirrtail

Abrasive formations, bent drill rod, seriously worn stabilizer and insufficient air for drilling rate attained etc, are all the causes which result in premature shirrtail wear. In this case, the configuration of cones is good and the amount of inserts wear is small. Shirrtail wear can also allow the big roller bearings to fall out resulting in bit failure.

Method: The designer should strength the shirrtail with certain measures to increase the wear-resistance capacity of shirrtails.

2. Early wear and loose movement of the bearing

A. Excessive weight on bit can shorten the service life of bit bearing.

B. Insufficient air to clean the hole and/or cool the bearing, leads to bearings overheating due to improper cooling and poor cuttings removal, and results in rapid decrease of bearing life especially in a wet hole or where water section is used.

3. Cutting structure failure

A. Excessive WOB or Rotation speed.

B. Wrong bit selection, e.g. to drill extremely Rock by medium hard type bit.

C. Cuttings blowing in bad contitions caused repeating crushing.

Method: With better understanding rotary drilling technique, you can correctly select operating parameters and rotary types for your specific working conditions so that you will succeed in getting satisfactory drilling results.

II Examples of product failures

Broken teeth

	Failure description
	Teeth break flush to cone body
	Causes
	<ol style="list-style-type: none"> 1. Too high RPM 2. Broken, disintegrated formation while drilling or spudding a well 3. Improper bit 4. Alteration of formations including very hard ones.
	Recommendation
	<ol style="list-style-type: none"> 1. Reduce the RPM 2. Decrease the drill pressure and speed per minute when encountering extremely hard rock formations 3. The construction of the bit is selected according to the working condition.

Chipped teeth

	Failure description
	Chipped tungsten carbide inserts
	Causes
	<ol style="list-style-type: none"> 1. Excessive WOB 2. Broken, disintegrated formation while drilling or spudding a well 3. Wrong TCI grade 4. Cone interference
	Recommendation
	<ol style="list-style-type: none"> 1. Revise the drilling applications and WOB 2. Reduce WOB and gradually reduce RPM.

Lost teeth

	Failure description
	TCI fall out of the cone body
	Causes
	<ol style="list-style-type: none"> 1. Metal on the bottom hole 2. Cone erosion 3. A crack in the cone that loosens the grip on the insert 4. Excessive WOB.
	Recommendation
	<ol style="list-style-type: none"> 1. Reduce WOB and RPM as an option you can use both actions 2. Select a bit that is more suitable for the application.

Worn teeth

	Failure description
	<p>Inserts wear blunt. Slow penetration rates</p>
	Causes
	<ol style="list-style-type: none"> 1. Excessive WOB 2. Carbide grade does not match the rock properties 3. Formations changed and are interbedded with hard abrasive stringers 4. Excessive RPM
	Recommendation
	<ol style="list-style-type: none"> 1. Reduce WOB and RPM as an option you can use both actions 2. Select a bit with another shape of inserts and with a more wear resistant carbide grade 3. Select a bit that is more suitable for the application.

Heat checking



Failure description

Inserts surface is worn and looks like a "snake skin" It often results in inserts breakage

Causes

1. Carbide grade does not match the formations drilled
2. Inserts are heated by drilling process and at the same time are cooled with water, injected into the well with air and by underground water.

Recommendation

1. Select a bit with carbide grade less prone to heat checking (higher cobalt content or bigger grain size)
2. Reduce RPM and water supply.

Tracking



Failure description

Inserts are worn mainly on one side. This is a dull characteristic that occurs when the inserts mesh like a gear into the bottom hole formation.

Causes

1. Improper WOB and RPM
2. Improper bit selection
3. Changes of the formation.

Recommendation

1. Adjust WOB and RPM so that the proper rock cutting within a certain period of time is achieved
2. Select a bit better suited for the application or a bit with an irregular skip pitch.

Erosion

	Failure description
	<p>Cone steel erodes away round the inserts and results in loss of inserts. Also, excessive leg erosion can result in loss of inserts on the legs and</p>
	Causes
	<ol style="list-style-type: none"> 1. High abrasiveness of the formations drilled 2. Inadequate air volume flowing through the nozzles 3. Wet (from either ground water or excessive water injection) sticky and abrasive formations.
	Recommendation
	<ol style="list-style-type: none"> 1. Select WOB and RPM to achieve maximum ROP 2. Inspect air supply system for leakage 3. If water dust control is used, reduce water supply, Make sure that the nozzles are not lugged 4. Inspect cutting removal efficiency 5. Increase nozzle size to reduce air pressure.

Lost cone

	Failure description
	Cones are left at the bottom hole
	Causes
	<ol style="list-style-type: none"> 1. The bit overdrilled the bottom hole 2. Bit shock problem 3. Bearing failure (all rollers and balls fell out)
	Recommendation
	<ol style="list-style-type: none"> 1. Observe instructions in the bit manual 2. Monitor and control wear of the drilling rod threaded joints.

Cone interference

	Failure description
	<p>Bearing wear results in the teeth (inserts) of one cone interfering with another cone. It often results in intermittent cone jamming and inserts</p>
	Causes
	<ol style="list-style-type: none"> 1. Excessive WOB resulting in exaggerated bending moment of journals 2. Plugged air passages, as a result bearings are not properly cooled 3. Insufficient air volume supplied to the bearing 4. Running a bit in an under-gauge well 5. Rollers and balls fall out of one cone.
	Recommendation
	<ol style="list-style-type: none"> 1. Reduce WOB 2. Inspect drilling rods condition, their wear and deviation 3. Inspect drilling assembly bushings for wear 4. Check the back pressure valve availability as well as nozzles availability and proper

Lost nozzle



Failure description

A lost nozzle usually results in a sharp pressure drop and requires an immediate bit pulling out

Causes

1. Breaking the rules of nozzle installation
2. Mechanical damage of nozzles or their retention system
3. Nozzles or their fixture erosion.

Recommendation

Examine the bit after each drilled

Cone dragged

	Failure description
	<p>All three cones are jammed. The cones have typical tracks (flats) caused by inserts sliding at the bottom hole</p>
	Causes
	<ol style="list-style-type: none"> 1. Drilling with an air compressor switched off or failed 2. Air supply stopped or is insufficient due to air hose tear or air leakage in the circulation system 3. A foreign object jammed between the cones 4. Bit balling up.
	Recommendation
	<ol style="list-style-type: none"> 1. Repair and adjust the compressor 2. Eliminate air leakage

Balled-up bit

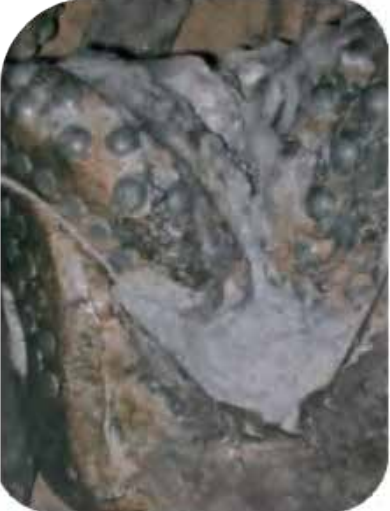
	Failure description
	<p>Formation is packed between the cones. It can be erroneously considered as the bearing being</p>
	Causes
	<ol style="list-style-type: none"> 1. Inadequate cleaning of the bottom hole 2. Running the bit in hole with the compressor being off 3. Drilling a sticky formation.
	Recommendation
	<ol style="list-style-type: none"> 1. Increase the air flow rate by nozzles selection 2. When you plan a blackout, inform the drilling rig operator in advance 3. Examine the bit after each drilled well.

Broken leg

	Failure description
	One or all three legs are missing. It often happens as a result of the operator's error or equipment failure
	Causes
	<ol style="list-style-type: none"> 1. The drilling rod lost in the hole while tripping or repair 2. High abrasiveness of the formations drilled
	Recommendation
	<ol style="list-style-type: none"> 1. Periodically check the thread of the drilling rod, In case of a wear or thread damage replace the thread connection 2. Select the optimal nozzle diameter

Cone broken

	Failure description
	The cone cracks either axially or circumferentially
	Causes
	<ol style="list-style-type: none"> 1. Cone steel fatigue 2. Cone interference making the cone heat and generate cracks 3. Excessive WOB 4. Dropped drilling rod
	Recommendation
	<ol style="list-style-type: none"> 1. This dull characteristics can be allowed if the bit is run for a long time 2. Reduce WOB 3. Review the drilling applications and make sure that the bit drills the bottom hole smoothly with no impacts

Cored bit

	Failure description
	Nose parts of the cones are missing or worn
	Causes
	<ol style="list-style-type: none"> 1. Excessive WOB resulting in the cone body coming in contact and hitting against the bottom hole 2. Inadequate hole cleaning causing cone erosion 3. Cone noses of the bits with central nozzle wear badly while drilling abrasive formations due to sand blasting effect resulting in lost inserts and worn noses 4. Junk on the bottom hole
	Recommendation
	<ol style="list-style-type: none"> 1.Reduce WOB 2. Select inserts projection, shape, diameter and quantity so that the cone body would not contact or hit against the bottom hole 3. Measure the actual compressor capacity, drilling rod diameter and check the nozzles selection 4. Replace the bit with a central nozzle by a bit with side nozzles only

Rounded gauge



Failure description

The gauge inserts are rounded towards the centre of the bit.
Slow penetration rates

Causes

1. Excessive RPM
2. Carbide grade does not match the formation hardness

Recommendation

1. Reduce RPM
2. Use a bit with a more wear resistant carbide grade
3. Use a bit with less offset and a bigger journal angle

Plugged nozzle

	Failure description
	A nozzle is plugged with cuttings or rubber hose scraps.
	Causes
	<ol style="list-style-type: none"> 1. The bit was left at the bottom hole with air off for work-over and for power transmission line switching 2. The bit valve protecting from cuttings failed or is missing 3. The compressor failed, the hose fell off
	Recommendation
	<ol style="list-style-type: none"> 1. Use a dull bit for work-over 2. When you plan a blackout, inform the drilling rig operator in advance 3. Periodically check the relieve valve of the bit, its operability and fixture reliability, Replace the valve if necessary 4. Do not use bits that have no valve protection from cuttings 5. Adjust the compressor, eliminate air leakage, clean the bit from cuttings

Bearing sludging

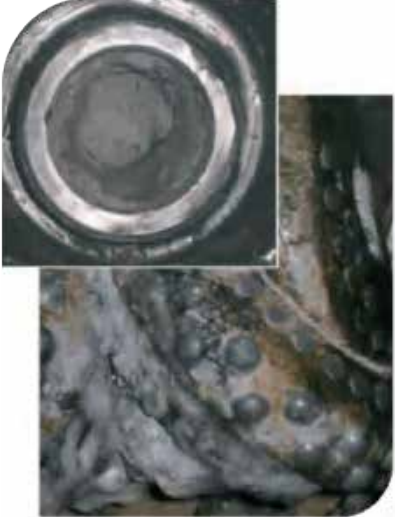
	Failure description
	Sludge in the bit bearing
	Causes
	<ol style="list-style-type: none"> 1. Insufficient compressor capacity 2. Improper nozzles selection 3. Drilling without the relieve valve 4. The bit was left at the bottom hole for a long time with the compressor off
	Recommendation
	<ol style="list-style-type: none"> 1. Select the nozzles according to recommendation 2. When you plan a blackout, inform the drilling rig operator in advance 3. Run the bit with a relieve valve in place

Shirrtail wear

	Failure description
	Leg shirrtail protecting the bearing is broken
	Causes
	<ol style="list-style-type: none"> 1. Axial part of the load on the bearing results in the shirrtail bearing a part of the load 2. Axial runout when the bit rotate 3. Erosion weakens the shirrtail structure
	Recommendation
	<ol style="list-style-type: none"> 1. Reduce WOB and select a bit with a smaller journal angle and bit axis 2. Check the bit for off-centre wear and the drilling rod for a bent 3. Check the bit thread and the sub thread for damage 4. Check the drilling rod, compressor and the air line for leakage

Off-center wear

	Failure description
	Excessive wear of one or two legs (legs, shirttails); of one or two cones (gauge and hill rows), along with bearings failure; cones jammed and balls and rollers lost
	Causes
	<ol style="list-style-type: none"> 1. The drilling rod is bent which results in off-centre bit rotation (radial runout) 2. The bit is screwed to the above bit sub with a warp, the bit thread is damaged 3. The thread of the sub (box) is not cut properly, the thrust face of the sub does not thrust against that of the bit 4. Hoisting jack has failed
	Recommendation
	<ol style="list-style-type: none"> 1. Check the drilling rod rotation for eccentricity 2. Check the bit for damaged thread 3. Check and replace the top sub if its thread is damaged

